

# Operating Instructions



## DUNOS R / RW



---

These operating instructions are part of the cleaner and must be at the user's disposal at any time. Every safety instruction is to be made sufficiently known and to be observed. If the unit is passed on, the operating instructions must be passed on as well.

---

# Content

## **1 GENERAL INFORMATION**

[1.1 Function](#)

[1.2 Design](#)

[1.3 Application](#)

## **2 TECHNICAL DATA**

[2.1 Dimensions](#)

[2.1.1 DUNOS R](#)

[2.1.2 DUNOS Rw](#)

[2.2 Flow and throw length](#)

[2.2.1 DUNOS R](#)

[2.2.2 DUNOS RW](#)

## **3 SAFETY INSTRUCTIONS**

## **4 DANGERS**

## **5 MOUNTING AND MAINTENANCE**

[5.1 Mounting](#)

[5.2 Commissioning](#)

[5.3 Maintenance](#)

## **6 INTEGRATION AND CONTROL**

[6.1 Integration into a cleaning system](#)

[6.2 Control over hand control elements](#)

## **7 TROUBLE-SHOOTING**

[7.1 Emergency stop](#)

## **8 TRANSPORT**

**8.1 Delivery scope**

**8.2 Transport and packaging**

## **9 QUALITY ASSURANCE**

## **10 DISPOSAL**

## **ANNEX**

### **I. SYMBOLS**

### **II. TERMS USED**

### **III. LIST OF FIGURES**

# 1 General information

## 1.1 Function

DUNOS R/RW are rotating surge cleaners which are powered by the medium flowing through. The cleaners consist of a number of components being as small as possible. The machines are designed with minimum clearance volume and produced of controlled materials in Germany. The surfaces and their roughness are already controlled during production.

The cleaning agent is fed into the surge cleaner over a pre-filter (200µm). The surge cleaner is lowered into the vessel over a pipe.

The machine basically consists of the cleaning head with rotor and surge nozzles.

The rotation of the cleaning head is obtained by means of the asymmetric design and arrangement of the surge nozzles. Owing to the intelligent design of the surge cleaner head, the medium flowing through is not only used for the generation of the rotation, but also for the generation of an almost wear-free hydraulic bearing.

The surge cleaners can be operated with a wide range of head and nozzle diameters resulting in a perfect adaptation of the units to the cleaning task.



Fig. 2: DUNOS RW

## 1.2 Design

The surge cleaner basically consists of

- **Connecting piece**
- **Stator**
- **Plain bearing and**
- **Rotor with nozzle system.**

The universal surge spraying head can be fitted with different nozzle systems.

Options:

- The function of the surge cleaner can be safely monitored (monitoring of rotation) or/and
- A defined slow speed of the surge jet can be achieved by means of the integration of the AquaDuna fluid drive (10-15 u/min; the longer dwell time of the surge cleaner at one spot of the vessel produces a much better cleaning effect)

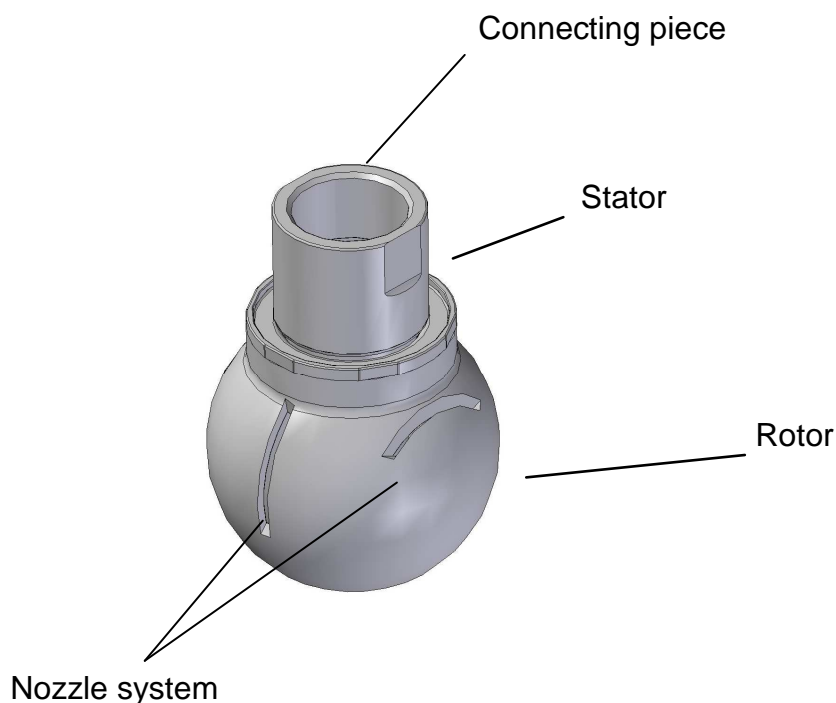

Fig. 3: Design DUNOS R

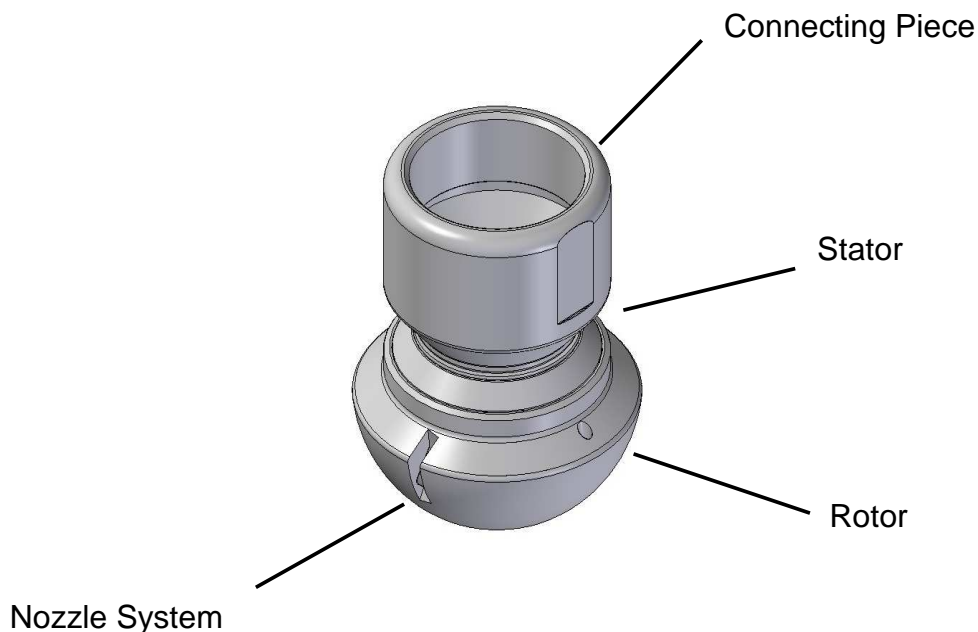

Fig. 4: Design DUNOS RW

### 1.3 Application

The surge cleaners of series DUNOS are medium-driven cleaning machines. The rotation of the cleaning head is made via the forces acting during the flow and the exit of the medium jet.

The surge jets coming out of the nozzles impact the vessel wall with a large-surface surge. The arising washing forces remove the deposits from the vessel wall. Depending on the deposit to be removed, it is recommended to add a portion of chemicals which is determined by the respective user.

The unit is made of stainless steel 316 L, PTFE and PEEK. It resists to the chemicals usually used in the pharmaceutical and food industries.

We optionally supply to you surge cleaners made of special materials, such as Hastelloy or glass-fiber reinforced PTFE.

The units may be used only in closed vessels. Operation outside the vessel may lead to injuries.



These surge cleaners are designed to be used only inside closed vessels and may be used only in the intended ranges. Any application other than intended is forbidden. Application may be made only by qualified and instructed persons.

Modifications are not covered by the manufacturer.

---



## 2 Technical data

<b>DUNOS</b>	<b>R15</b>	<b>R32</b>	<b>R60</b>	<b>R90</b>
Built-in diameter	DN 25	DN 50	DN 80	DN 125
Medium connection (screw)	IG 1/8"	IG 3/8"	IG 3/4" / 1"	IG 2"
Medium connection (splint)	Ø10	Ø13/Ø18	Ø25,4/Ø29	Ø41/Ø52
Number of nozzles	2 – 5	2 – 5	2 – 8	2 – 20
Shape of nozzles	various	various	various	various
Work pressure	1-8 bar	1-8 bar	1-8 bar	1-8 bar
Volumen flow	up to 0.5 m³/h	up to 4 m³/h	up to 10 m³/h	up to 16 m³/h
Cleaning radius	up to 0.75 m	up to 2 m	up to 2.5 m	up to 3.5 m

<b>DUNOS</b>	<b>RW27</b>	<b>RW35</b>	<b>RW50</b>
Built-in diameter	DN 32	DN 40	DN 65
Medium connection (screw)	IG 1/4"	IG 3/4"	IG 3/4" / 1"
Medium connection (splint)	Ø13	Ø17	Ø28/Ø33,7
Number of nozzles	2 – 5	2 – 5	2 – 5
Shape of nozzles	various	various	various
Work pressure	1-8 bar	1-8 bar	1-8 bar
Volumen flow	up to 2.5 m³/h	up to 4 m³/h	up to 6 m³/h
Cleaning radius	up to 1.5 m	up to 2 m	up to 2.5 m

Temperature range: 4 - 120 °C

Materials: Stainless steel 316L  
PEEK  
PTFE  
PTFE, glass-fiber reinforced

Accessories (optional): Rotation control  
Connecting pieces  
Special nozzles

### Additional data with ATEX

T category (fuel gas)	T4
Maximum temperature value of temperature category	120°C
Max. temperature of cleaning agent and vessel	97°C
Maximum surface temperature of dust	120°C

(according to standard DIN/EN 1127-1, the maximum surface temperature of the cleaning unit must not exceed 2/3 of the ignition temperature of the dust cloud. In addition to that, only dusts are permitted whose glow temperatures having a safety distance of 75 K, exceed the maximum surface temperature)

Cleaning agent	based on water, liquid
Max. vessel size to be cleaned	100m <sup>3</sup>
Conductivity of the cleaning agent	>1 µSiemens/m
Maximum cleaning agent pressure	12 bar



In case of application in an explosive ambience, the specifications of the ATEX release of the certified testing institute must be observed as well.  
If necessary, you can ask for a copy of the Technical Report from the manufacturer.

---



The maximum medium temperature as well as the maximum work pressure must be safely monitored by the operator. In case the limit values are exceeded, the supply must be stopped.

---



The rotational cleaner must **NOT** be used for the cleaning of vessels in which there are explosive atmospheres of temperature class IIC.

---

## 2.1 Dimensions

### 2.1.1 DUNOS R15

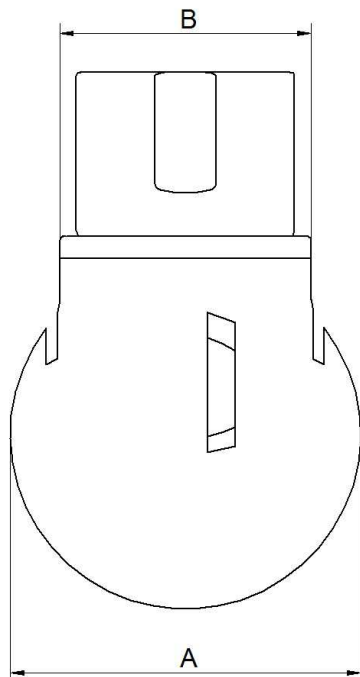

Fig. 5: Dimensions DUNOS R

Dimensions [mm]	A	B
DUNOS R15	Ø15,8	Ø12,8
DUNOS R32	Ø31,8	Ø22,8
DUNOS R60	Ø59,8	Ø42,8
DUNOS R90	Ø94,8	Ø67,8

## 2.1.2 DUNOS RW

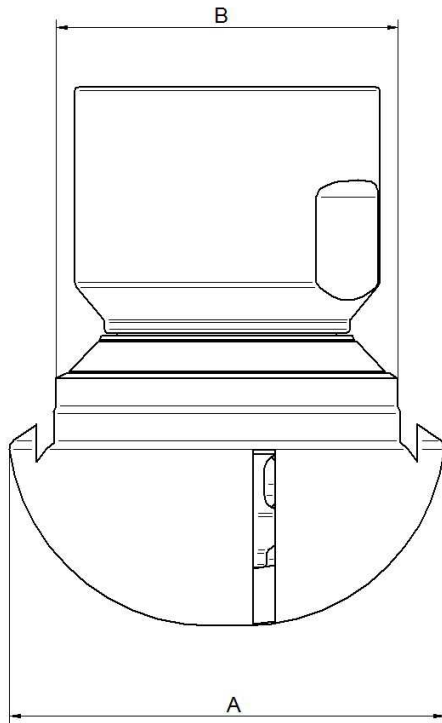

Fig. 6: Dimensions DUNOS Rw

Dimensions [mm]	A	B
DUNOS Rw27	Ø27	Ø20
DUNOS Rw35	Ø34,9	Ø27
DUNOS Rw50	Ø49,7	Ø39

## 2.2 Flow and throw length

### 2.2.1 DUNOS R

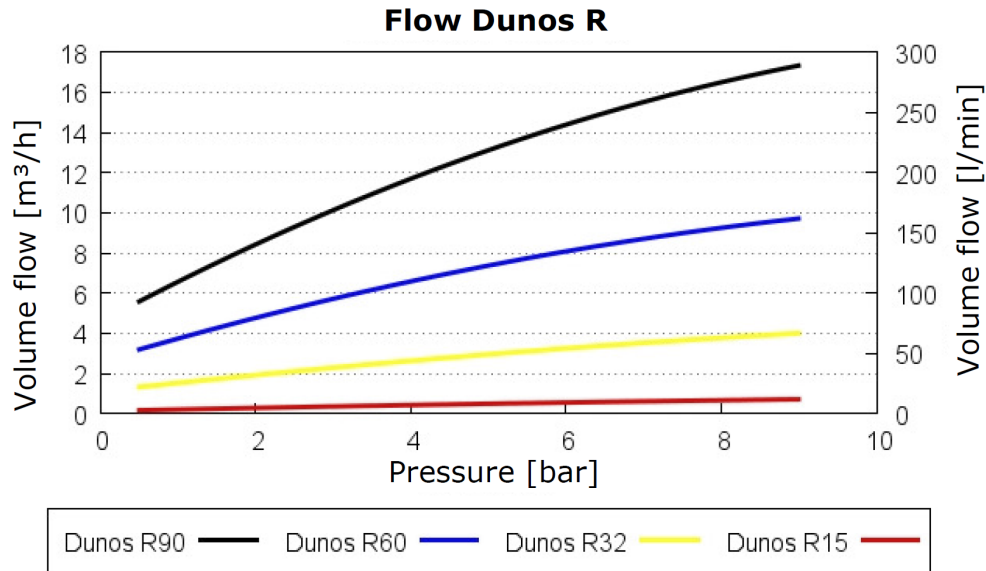

Fig. 7: Flow DUNOS R

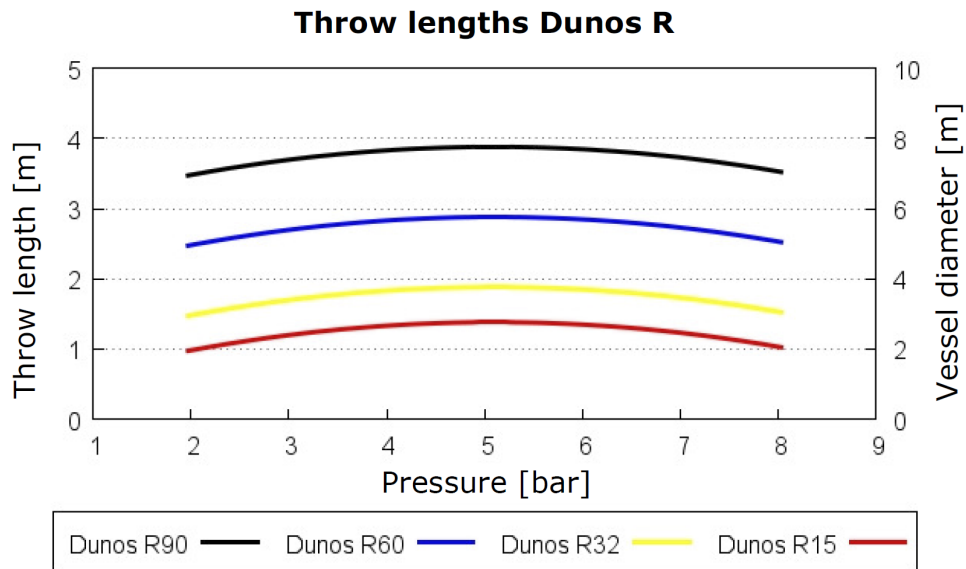

Fig. 8: Throw lengths DUNOS R

## 2.2.2 DUNOS RW

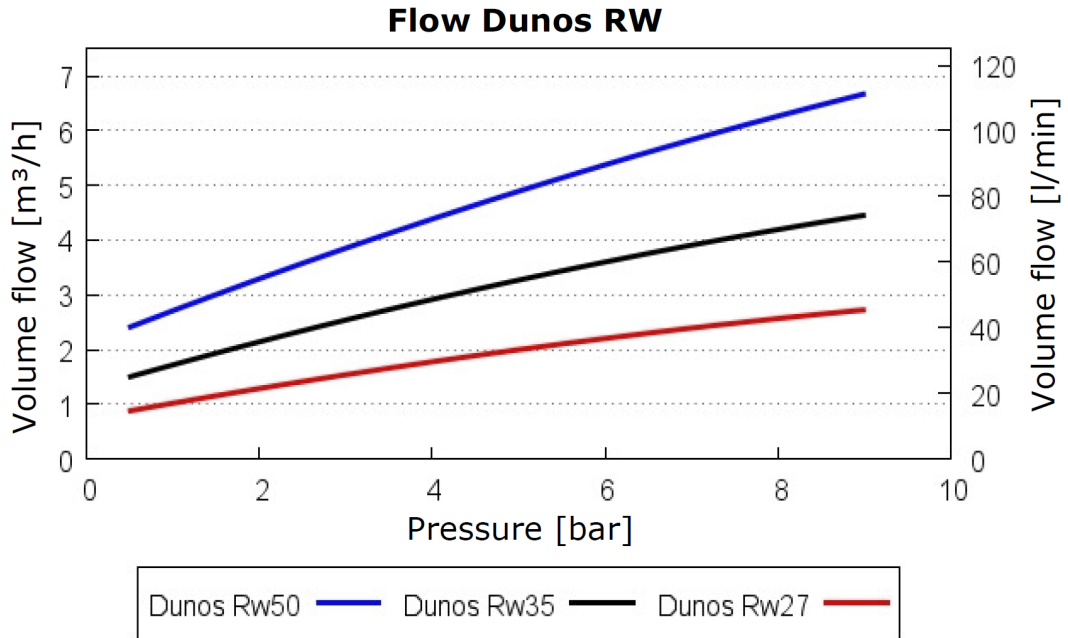

Fig. 9: Flow DUNOS RW

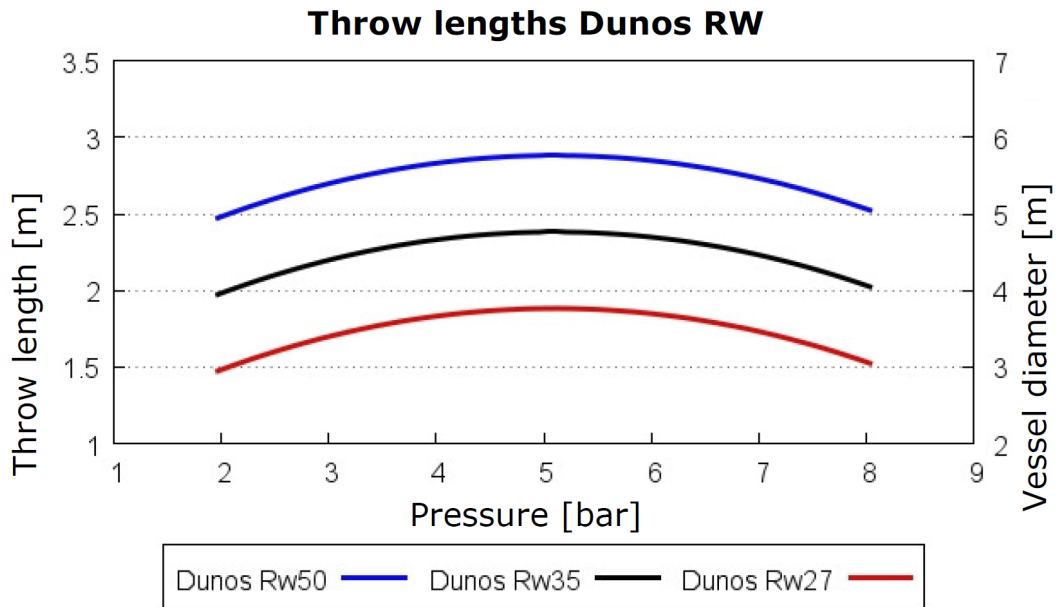

Fig. 10: Throw lengths DUNOS RW

### 3 Safety instructions

The operator of the surge cleaner is obliged to train the operating personnel as well as the personnel authorized to carry out the maintenance. Everybody who works at rotating and spraying machines, must be informed about the dangers that these machines may present.

Persons being not listed as operating and maintenance personnel, are not allowed to stay in the working range of the machine. The operator must see to the necessary measures to be taken.

Basically, the machines are maintenance-free. Possibly necessary repair works may be made only by the manufacturer. In case of non-observance, warranty will be lost.

### 4 Dangers



The surge cleaners are exposed to high pressures. Notification is hereby made that repair / maintenance may be made only by the manufacturer. Damages which may result from the non-observance of the instruction, **won't be accepted** by the manufacturer.



The surge cleaner may be operated only in the ambiance intended for it. Operation is allowed only in closed vessels / rooms. Pay attention to rotating parts.



When working with the surge cleaner, make sure that your hands can't get caught between possible nozzles and unit body.



Only authorized persons are allowed to stay in the operational area of the surge cleaner.

## Commissioning



1. When mounting the machine, secure it against tilting and twisting.
2. Mount all fastening points in a professional way.
3. Feeding pipe of the cleaning agent must be interrupted and secured against opening.
4. Any cleaning agent must not be in the feeding pipe.
5. Hot steam pipes must be interrupted.
6. Start machine only in closed vessels.
7. Assembly of the machine only with appropriate equipment.
8. Test visually the surge cleaner for leak, by increasing slowly the operating pressure. Avoid pressure impacts.

### Additional instructions for ATEX type



1. In case of ATEX type, make sure that a sufficient safety distance of 200 mm at least between the moving parts of the surge cleaner and the vessel wall or other built-in units, such as agitators etc., is kept. The surge cleaner is designed in a way that all parts are linked together.
2. Prior to commissioning, an equipotential bonding must be assured by means of an appropriate connection with the complete system. The shunt must be  $<10^6 \Omega$ . This must be checked always before recommissioning.
3. Use only a cleaning liquid having a conductance of  $>1 \mu\text{Siemens/m}$ .
4. It is allowed to clean only conductive, earthed vessels.
5. Any chemical reaction must not be generated which is caused by the cleaning agent and the material to be cleaned, which may result in an ignition source.
6. Turbulences and electrostatic charges may be generated during cleaning due to the drops of the cleaning jet. This is closely linked to the cleaning liquid used and the process parameters applied, such as pressure, volume flow and temperature. If the indicated performance characteristics are kept, no dangerous charge will be produced.



## Operation



1. Never start the machine outside the vessel.
2. Observe technical data (pressure, temperature etc.).
3. Stop the machine immediately in case of trouble and make rectify the faults by a trained, authorized and qualified personnel.
4. Make sure with appropriate safety measures that all feeding pipes toward the machine are interrupted, if vessel is open.

### Additional instructions for ATEX type:

According to commissioning.

## Disposal



Rinse machine with appropriate neutralization agent before disposal.

## 5 Mounting and maintenance

### 5.1 Mounting

The surge cleaner is connected to the medium feeding pipe of the system over the connecting piece (female thread, fastening split-pin or specified by the customer). When fixing the machine, make sure that the machine is firmly connected to the supported element.



Before starting the machine, always check that all parts are fixed. In case the machines are not correctly mounted, the operator himself will be liable.

### 5.2 Commissioning

As soon as all pipes and feeding pipes toward the surge cleaner are firmly connected and the valves are closed, the surge cleaner is prepared to be set into operation for the first time.

The function of the pre-filter in the feeding pipe toward the surge cleaner must be checked and the filter body must be inserted.

Prior to commissioning, the feeding pipe toward the surge cleaner must be rinsed. Metallic impurities and welding residues may damage the surge cleaner.

During commissioning make sure that the feeding pipe toward the surge cleaner has been deaerated particularly in case of long feeding pipes in order to avoid pressure impacts which may damage the surge cleaner.



If hand-operated valves are used, those must not be opened abruptly in order to avoid pressure impacts.

In case of operation in automatically cleaning systems, the operators must familiarise with cutoff and/or emergency stop.

## 5.3 Maintenance

The surge cleaners are generally maintenance-free.

However, residues of the cleaning agent must be removed by rinsing with a neutralizing flushing agent after every application of the surge cleaner. Then a function control as well as an optical test are to be made in order to check if the surge cleaner is damaged. Only undamaged surge cleaners may be used.

Only the manufacturer is permitted to make a possibly necessary repair of the surge cleaner head.



Notification is hereby made that, according to the Product Liability Law, we are not liable for damages caused by our device in case they were caused by incorrect repair works.

---

## 6 Integration and control

### 6.1 Integration into a cleaning system

If the surge cleaner is integrated into an automatically working system, make sure that the function of the surge cleaner can be monitored. This can be done by means of a rotation control or by an optical control. The function control must be documented in case of optical inspection (system log).

### 6.2 Control over hand control elements

If the surge cleaner is controlled via hand control elements, make sure that impacts are avoided. Therefore the operating elements must be slowly opened and closed. In case they are exposed to steam, make sure that the temperature does not exceed the limits determined. A monitoring of the surge cleaner must be guaranteed.

## 7. Trouble-shooting

### 7.1 Emergency stop



In order to force an emergency stop of the surge cleaner, the operators of the system must absolutely familiarise with the plant design. It is essential to train an emergency stop and to inform about the necessary elements regarding an emergency stop. The training of the persons who were charged with the cleaning, must be documented. Every damage to person and property which result from faulty operation or faulty application, are borne by the plant operator.

## 8 Transport

### 8.1 Delivery scope

The complete surge cleaner and the operating instructions for the respective type are included with the delivery.

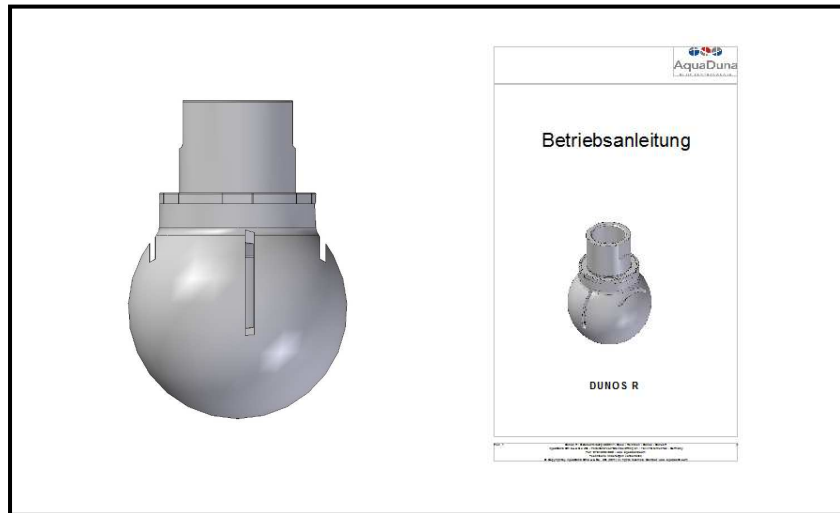

Fig. 11: Delivery scope



You can learn the options from the shipping documents.

### 8.2 Transport and packaging

Our products are carefully produced, mounted and tested. Should there be any reason for complaint, we will naturally give you entire satisfaction within the scope of our warranty. We will be pleased to help you after expiry of warranty, too.



When receiving a delivery, always check the packing list against the delivery scope. After having noticed that delivery is complete, the goods must be checked for damage.

If there are damages, it is essential to note them down on the shipping documents. In case of damage, the forwarder must countersign the documents.

If parts are returned, either keep the outer package or use a packaging where the devices are not damaged.

## 9 Quality assurance

We take quality in design, production, assembly, final inspection and control for granted. It is the sine qua non for a permanently efficient and high-quality production of our demanding products. In order to guarantee our high-quality standards, we use a computer-assisted quality assurance system which we have applied for certification according to ISO 9001:2008. In addition to that, all our products are subjected to a final function test (100% control). We herewith assure that only perfectly working products leave our company.

## 10 Disposal

All materials used for the production of the surge cleaner are not harmful to the environment. The mostly used materials are stainless steel, PTFE, PEEK and glass fiber. You can dispose of them over the ways intended.



### **ATTENTION!**

Make sure that there are not contaminations with material from operation anymore. If so, the corresponding material for rinsing of the parts to be disposed, must be used.

# Annex

## I. Symbols

### Hazard notes



The warning triangle informs about special risks.



Hazard of hand injury



Hint to rotating system parts

### Warnings



Danger warning

### Information



Observe operating instructions



Observe information

## II. Terms used

Fluid drive	Drive through fluid
PEEK	Polyetheretherketone
PTFE	Polytetrafluoroethylene
Stainless steel 316L	Austenitic, stainless steel. e.g. X2CrNiMo17-12-2

## III. List of figures

Fig. 1	DUNOS R
Fig. 2	DUNOS RW
Fig. 3	Design DUNOS R
Fig. 4	Design DUNOS RW
Fig. 5	Dimensions DUNOS R
Fig. 6	Dimensions DUNOS Rw
Fig. 7	Flow DUNOS R
Fig. 8	Throw lengths DUNOS R
Fig. 9	Flow DUNOS RW
Fig. 10	Throw lengths DUNOS RW
Fig. 11	Delivery scope